

CHECK 508

HORIZONTAL SWING – BRONZE

200 lb. SWP-425°F-400 lb. WOG†-150°F
Bronze Regrinding Disc • Y-Pattern • Threaded Ends

SPECIFICATIONS

508	Conforms to: MSS SP-80. Type 3, Class 200, Threaded Ends.
------------	--------------------------------------------------------------

MATERIAL LIST

NO.	PART	MATERIAL	SPECIFICATION
1	Body	Cast Bronze	ASTM B 61
2	Cap	Cast Bronze	ASTM B 61
3	Disc	Cast Bronze	ASTM B 61
4	Lever	Cast Bronze	ASTM B 61
5	Pin	St. Steel	Commercial
6	Plug	Rod Brass	ASTM B 16
7	Retaining Ring	St. Steel	ASTM A276 TY 304

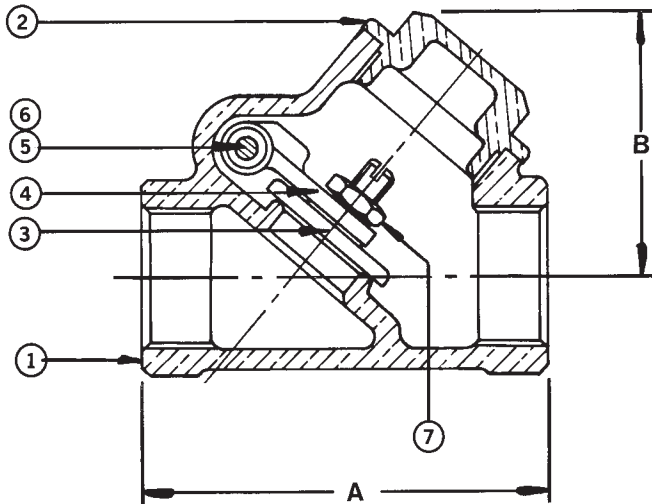

DIMENSIONS - INCHES / MILLIMETERS

Units	Size	A	B	C _v
Inches	1/4	2.25	1.63	2.3
mm	6.4	57.2	41.3	4.3
Inches	3/8	2.25	1.63	7.2
mm	9.5	57.2	41.3	13.0
Inches	1/2	2.63	1.75	22.0
mm	12.7	66.7	44.5	39.0
Inches	3/4	3.00	1.94	56.0
mm	19.1	76.2	49.2	92.0
Inches	1	3.69	2.50	150.0
mm	25.4	93.7	63.5	240.0
Inches	1 1/4	4.38	3.00	
mm	31.8	111.1	76.2	
Inches	1 1/2	4.63	3.31	
mm	38.1	130.2	84.1	
Inches	2	5.88	4.00	
mm	50.8	149.2	101.6	
Inches	2 1/2	7.00	4.75	
mm	63.5	177.8	120.7	
Inches	3	7.88	5.00	
mm	76.2	200.0	127.0	

† Non-Shock

Rev. 6

INNOVATION IN EVERY VALVE



MILWAUKEE VALVE

The information presented on this sheet is correct at the time of publication. Milwaukee Valve reserves the right to change design, and/or material specifications without notice. For the Installation, Operation and Maintenance Manual (IOM) see the engineering section on our website. For the most current information access www.milwaukeevalve.com

www.milwaukeevalve.com